

# KWC

ARMATUREN +  
ROBINETTERIE  
RUBINETTERIA  
GRIFERIA  
FAUCETS

## 802 108

07/04

Montage- und Serviceanleitung  
Instructions de montage et d'entretien  
Istruzioni di montaggio e di assistenza  
Instrucciones de montaje y servicio  
Installation and service instructions

**Badmischer**  
**Mitigeur bain-douche**  
**Miscelatore bagno-doccia**  
**Mezclador para baño**  
**Bath mixer**

**KWC ORCINO**  
**KWC DOMO**  
**KWC VITA-DUO**  
**KWC STAR**

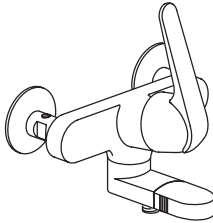

**KWC DOMO**  
**K.20.62.01**

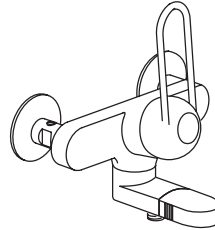

**KWC VITA-DUO**  
**K.20.T2.01**

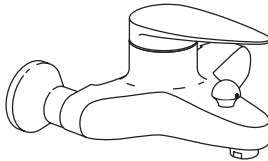

**KWC ORCINO**  
**K.20.72.01**

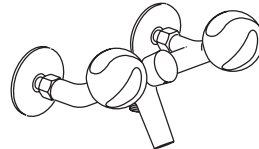

**KWC STAR**  
**K.20.42.20**

**Schweiz, Suisse:**

KWC AG  
Hauptstrasse  
CH-5726 Unterkulm

Tel. : 062 768 67 77  
Fax : 062 768 61 69

**Deutschland:**

KWC Deutschland GmbH  
Rigipsstraße 15  
D-71083 Herrenberg 6

Tel. : 07032-7809 0  
Fax : 07032-7809 30

**Oesterreich:**

Hansa Austria GmbH  
Rottfeld 7  
A-5020 Salzburg

Tel. : 0662 433 100 0  
Fax : 0662 433 100 20

**France:**

Hansa France  
Rue Ettore Bugatti  
F-67038 Strassbourg

Tel. : 0 388 78 88 08  
Fax : 0 388 76 55 32

**Italia:**

KWC Italia S.r.l.  
Via A. Meucci 54  
I-36057 Arcugnano (VI)

Tel. : 0 444 96 48 20  
Fax : 0 444 96 47 35

**USA:**

KWC Faucets Inc.  
1770 Corporate Drive #580  
Nordercross, Georgia 30093

Tel. : 678 334 2121  
Fax : 678 334 2128



Recyclingpapier auf 100% Altpapierbasis.  
Papier de recyclage sur 100% bases de vieux papier.  
Riciclaggio della carta sulla base della carta straccia di 100%.  
Reciclaje del documento sobre base del papel usado del 100%.  
Recycling paper on 100% waste paper basis.

**Betriebsdaten**

**Caractéristiques de fonctionnement**

**Caratteristiche di funzionamento**

**Datos de servicio**

**Operating data**



Ideal/idéale/ideale : 3 bar  
Max./mass./máxima : 5 bar

- D Druckgleichheit empfehlenswert.
- F Egalité de pression recommandée.
- I Si raccomanda pressioni uguali.
- Sp Se recomienda la igualdad de las presiones.
- E Equal pressures are recommended.

Ideal/idéale/ideale : 60 °C  
Max./mass./máxima : 80 °C

- D Vor Montage die Leitungen gründlich durchspülen!
- F Rincer à fond la tuyauterie avant le montage!
- I Risciacquare bene le tubazioni prima del montaggio!
- Sp Enjuagar escrupulosamente las tuberías antes del montaje!
- E Before installation flush pipes thoroughly!

**Inbetriebsetzung**

**Mise en service**

**Messa in funzione**

**Puesta en servicio**

**Taking into service**

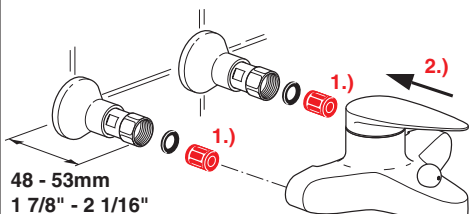

48 - 53mm  
1 7/8" - 2 1/16"

- 4.) |||| D spülen
- |||| F rincer
- |||| I sciacquare
- |||| Sp enjuagar
- |||| E flush

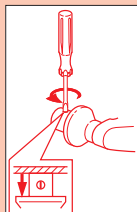

**Kalt- und Warmwasser öffnen.**  
**Ouvrir eau froide et chaude.**  
**Aprire acqua fredda e calda.**  
**Abrir la salida de agua fría y caliente.**  
**Open cold and hot water.**

**Höchsttemperaturbegrenzung**

**Limitation de la température max.**

**Limitazione della temperatura massima**

**Limitación de la temperatura máxima**

**Maximum temperature limitation**

**KWC ORCINO**

- D - Hebel und Kappe demontieren.
- Temperaturbegrenzungsring einstellen.



- F - Démontez le levier et la calotte.
- Régler l'anneau de limitation de température.



- I - Smontate la leva e la calotta.
- Regolate l'anello di limitazione della temperatura.

- Sp - Desmontar la palanca y el caperuzón.
- Ajustar el anillo de limitación de temperatura.

**KWC DOMO**

- E - Remove lever and cap.
- Adjust temperature reducing ring.

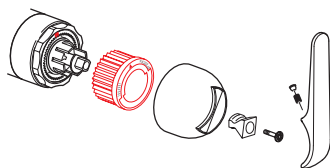

Max. Temperaturbereich :	Begrenzter Temperaturbereich :
Plage de température max. :	Plage de température réduite :
Campo di temperatura mass. :	Campo di temperatura ridotto :
Gama de temperaturas máx. :	Gama de temperaturas reducidas :
Max. temperature range :	Reduced temperature range :



Pfeil auf Kerbe.  
 Flèche sur encoche.  
 Freccia su scanalatura.  
 Flecha en la hendidura.  
 Arrow on groove.

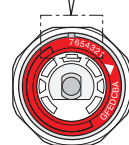
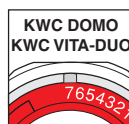

Ersatzteile

Pièces de rechange

Pezzi di ricambio

Repuestos

Spare parts

KWC ORCINO

KWC STAR

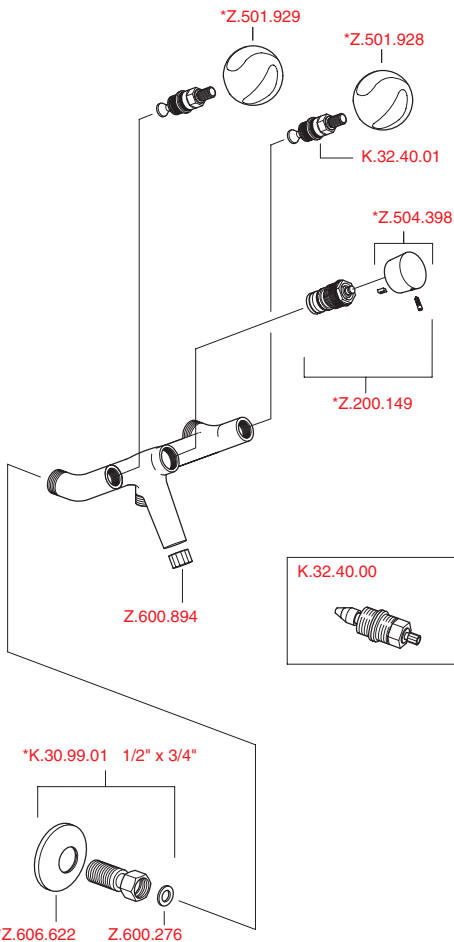
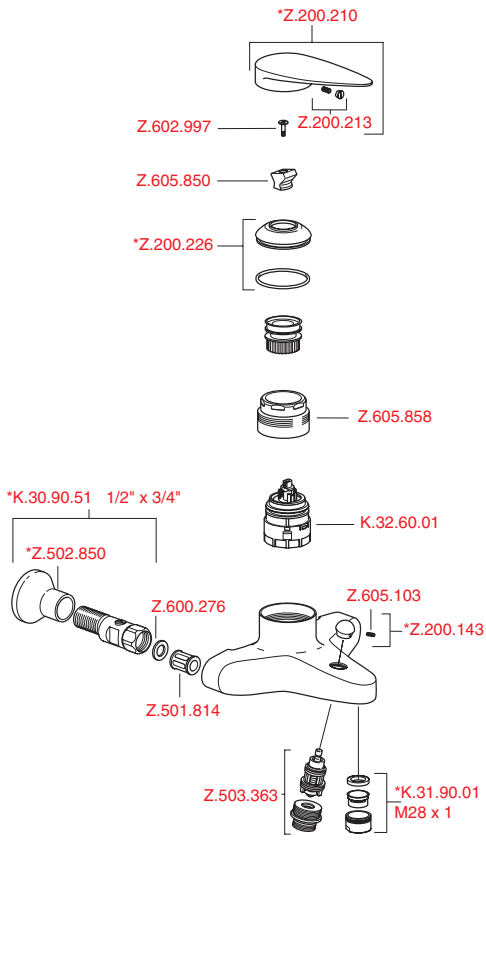

**D** \* Bitte bei Bestellung Farbe angeben.  
**F** \* Lors de la commande, veuillez indiquer la couleur, s.v.p.  
**I** \* P.f., nell' ordinazione indicare il colore.  
**Sp** \* Rogamos indique el color al hacer el pedido.  
**E** \* Please specify the color when placing your order.

KWC DOMO

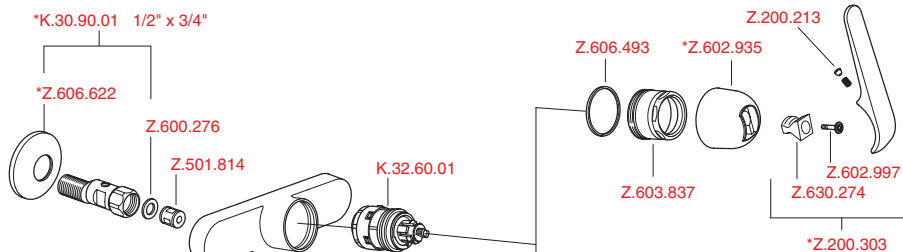

KWC VITA-DUO

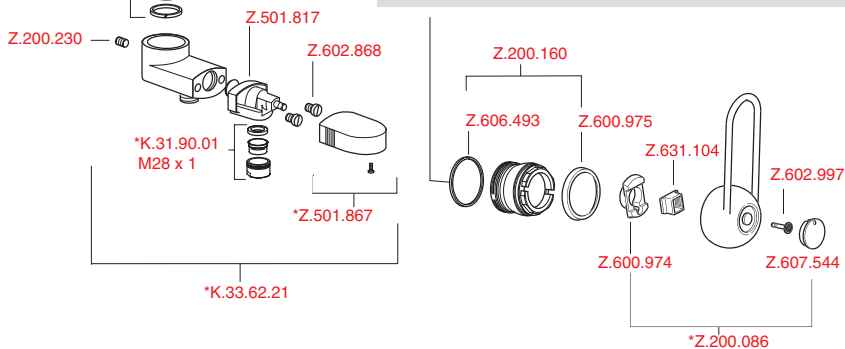

- D** Schäden, die infolge unsachgemässer Behandlung, natürlicher Abnutzung oder zu grosser Inanspruchnahme entstanden sind, sind von unseren Garantieleistungen ausgeschlossen!
- F** Ces dommages survenus en raison d'un traitement inadéquat, des signes d'usure traitement inadéquat, naturels ou du grand utilisation, sont exclus de notre garantie.
- I** Danni ai rubinetti, conseguenti da un trattamento non appropriato, sono esclusi dalla nostra garanzia!
- Sp** Daños, debidos a un tratamiento inadecuado, son excluidos de la nuestra garantía.
- E** Damages of the faucets as a results of incorrect handling are excluded from the manufacturers warranty!